

Intensive Quenching of Steel Parts

Michael A. Aronov, Nikolai I. Kobasko, and Joseph A. Powell, IQ Technologies, Inc.
George E. Totten, Portland State University

INTENSIVE QUENCHING is an alternative method of hardening steel parts. It provides extremely high cooling rates within the martensite-phase formation temperature range. This is in contrast to conventional quenching conducted in oil, polymer, or water that limits the cooling rate within the martensite formation range. This rule is based on the belief that slower cooling will avoid high-tensile residual stress, distortion, and a possibility of part cracking. Extensive research conducted by Dr. Kobasko in the early 1960s in the Ukraine demonstrated that avoiding a high cooling rate when material is in the martensite phase is not always necessary or optimal for obtaining the best material properties. His studies showed that a very high cooling rate within the martensite range would actually prevent quench cracking, if done correctly.

The process of intensive quenching (IQ) is a method of interrupted quenching conducted in highly agitated water. It differs from conventional oil, polymer, and water quenching by providing a much greater heat-extraction rate from the parts being quenched. The phenomenon was discovered first by laboratory experiments (Ref 1). Figure 1 shows experimental

data obtained for a cylindrical specimen made of low-alloy steel with a diameter of 6 mm (0.24 in.). The bell-shaped curve clearly illustrates a general effect of the cooling rate within the martensitic phase on crack formation: the probability of quench cracking is low for both the relatively slow conventional quenching and also for very rapid and uniform cooling (associated with the IQ process). Later, the IQ phenomenon was supported by the results of computer simulations and a large number of field experiments on a variety of actual steel parts.

Currently, two types of IQ methods are used in heat treating practice: IQ-2 and IQ-3. The IQ-2 process is a three-step procedure (referred to as an IQ-2 technique) based on fast cooling under quench nucleate boiling heat-transfer conditions on the part surface, slow cooling in air, and convection cooling in the quench tank. The IQ-2 process is usually applied to batch quenching. The IQ-3 process is a one-step intensive cooling method (referred to as an IQ-3 technique), where cooling at the part surface is so fast that both film boiling and nucleate boiling are completely avoided, and the basic heat-transfer mode on the part surface is simply convection. Direct convection

cooling is the key element of the IQ-3 process, and it is usually employed for single-part quenching operations.

This article provides a review of these methods and some applications. Basic principles, metallurgy, and practical applications of IQ methods for steel parts also are presented in numerous technical papers, conference proceedings, and books. A detailed description of the IQ technology, related equipment, and IQ applications is presented in the book *Intensive Quenching Systems: Engineering and Design* (Ref 3).

Mechanical Properties and Cooling Rate of Quenching

Figure 2 shows a general correlation between steel mechanical properties and the cooling rate of the part for both the conventional quenching process and the IQ process. Material mechanical properties improve with cooling rate increase during quenching, because the greater the rate of cooling, the deeper the hardened layer, and the more complete the phase transformation that takes place in steel parts.

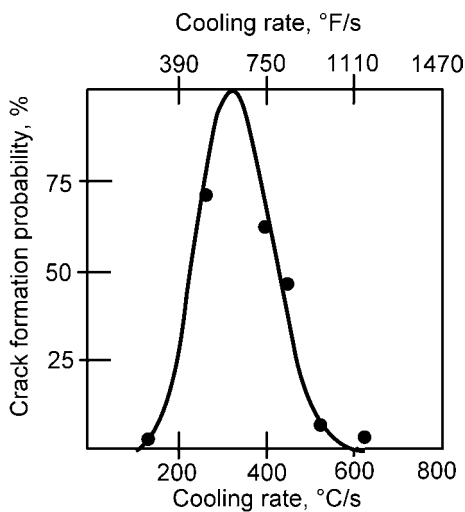

Fig. 1 Correlation between part cooling rate and probability of crack formation. Source: Ref 2

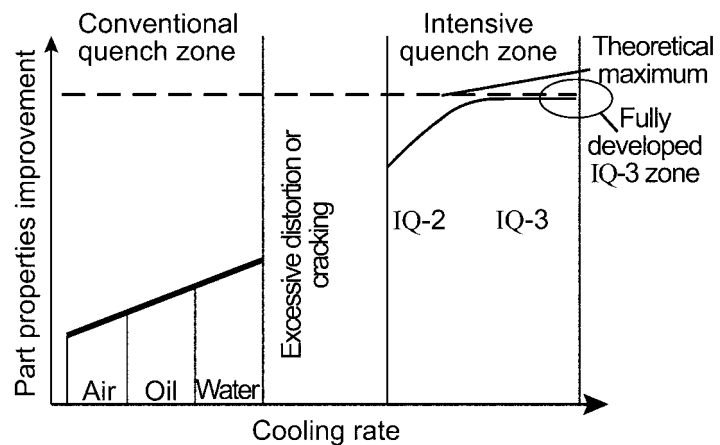

Fig. 2 General correlation between steel mechanical properties and cooling rate during quenching. IQ, intensive quenching. Source: Ref 4

The curve breaks between the conventional quenching zone and the IQ zone. This break illustrates that, in conventional quenching, the part will likely crack above a certain cooling rate. At that point, it is useless to quench faster and attempt to obtain any further improvements in the part mechanical properties on a distorted or broken part.

Figure 2 also shows that, in the IQ zone, part mechanical properties are not only greater compared to the conventional quench zone, but they continuously increase up to a certain ultimate level for the given steel type. When in the IQ zone, a faster quench rate on the part surface does not improve the part properties. This is because at the initiation of the IQ, the part surface temperature almost instantaneously becomes the same as the quenchant temperature. Said another way, after a certain intensity of quench (at a very high heat-extraction rate), the part cannot "give up" its heat any faster than the rate of heat conduction through the part. This is why one cannot quench too fast during the intensive portion of the quench. When the part surface layer has reached the temperature of the quenchant, conduction within the part sets a natural limit on the rate of cooling in the subsurface layers and the core

of the part. Because conduction is also a very rapid and a very uniform form of heat removal, intensive quenching is able to reach the ultimate goal of any quench.

Intensive Quenching and Other Quench Methods

As noted, the IQ process is an interrupted quench method conducted in highly agitated water. It differs from conventional oil, polymer, and water quenching by providing a much greater heat-extraction rate from the parts being quenched. Heat fluxes from the part surface during intensive quenching (and, as a result, the part cooling rates) are several times greater than that for conventional quenching (Ref 5, Chapters 3, 5, and 10). Extremely high heat-extraction rates result in a much greater temperature gradient throughout the part cross section. As shown subsequently, the temperature gradient is a major factor affecting the formation of very high current surface compressive stresses that prevent parts from cracking during intensive quenching. The residual surface stresses remain compressive after the IQ process is

completed. This is in contrast to conventional quenching, where residual surface stresses are usually tensile or neutral.

As an example, Fig. 3 to 5 illustrate the difference in thermal, structural, and stress conditions during the IQ process and conventional quenching in oil for a cylindrical rod of 25 mm (1 in.) diameter and made of plain carbon AISI 1045 steel. These data were generated by Deformation Control Technologies, Inc. of Cleveland, Ohio (Ref 6) using the DANTE computer program (Ref 7). As seen from Fig. 3, during IQ, the part core is still at the austenitizing temperature at a time when the martensite transformation begins on the part surface. A substantially deep part surface layer transforms into martensite by the time the phase transformation starts in the core. This is in contrast to conventional quenching in oil (Fig. 4), where the temperature lag from the part core to the surface is less than 50 °C (90 °F). This means that the phase transformation in oil takes place almost simultaneously through the entire part cross-sectional area.

Figure 5 shows a distribution of the calculated residual hoop stresses in the rod after IQ and after quenching in oil. As seen from the figure, the residual surface compressive hoop

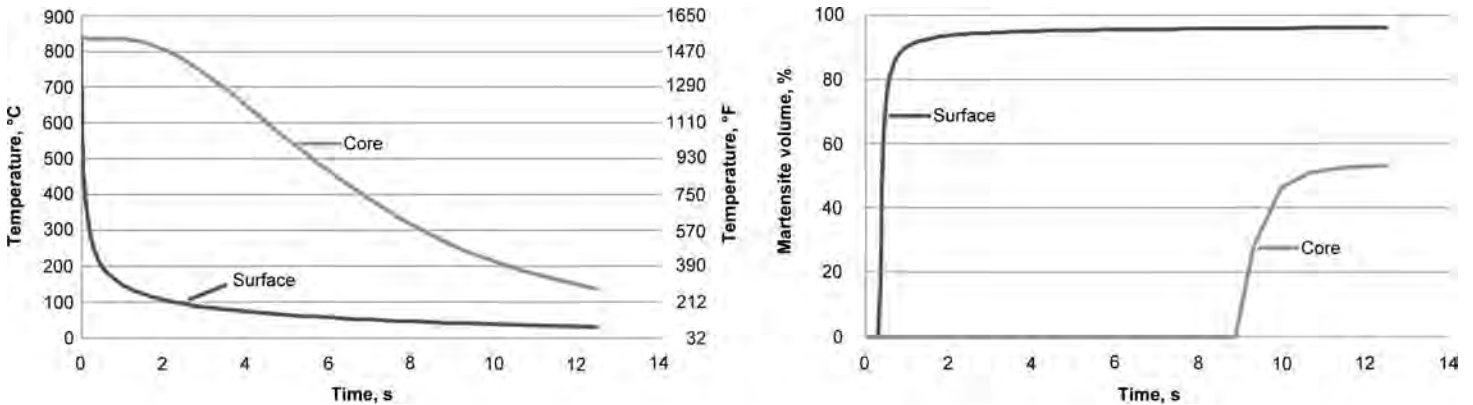

Fig. 3 Temperature and structural conditions during intensive quenching of 25 mm (1 in.) diameter rod made of 1045 steel

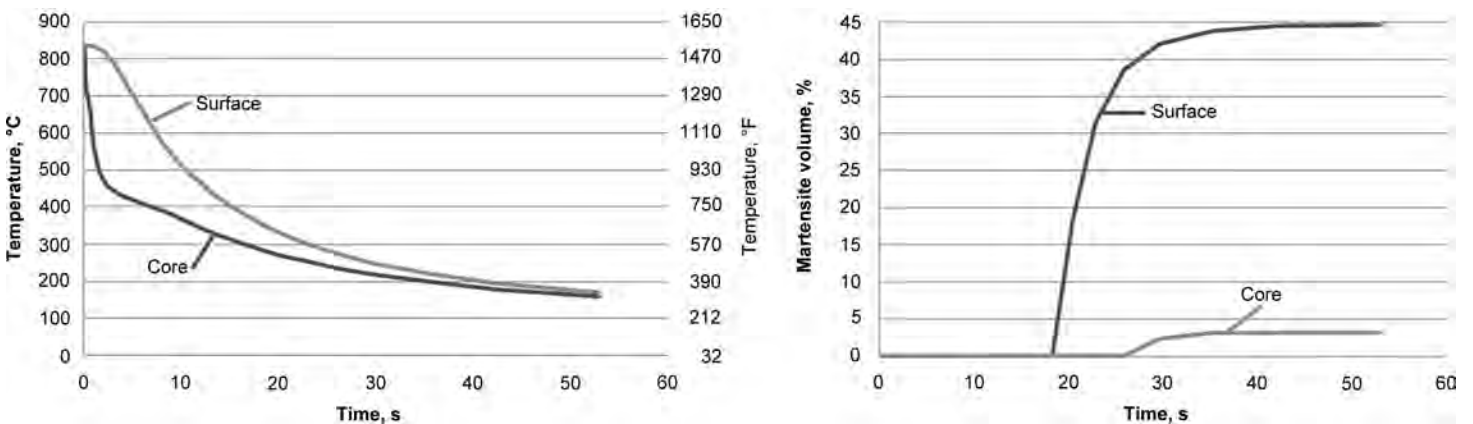

Fig. 4 Temperature and structural conditions during quenching in oil of 25 mm (1 in.) diameter rod made of 1045 steel

stresses after the IQ process are much greater compared to that after conventional quenching in oil. A value of the residual hoop surface compressive stresses after the IQ process is -1000 MPa (-144.7 ksi), while this value after oil quenching is only -294 MPa (-42.5 ksi). Two factors contribute to a higher value of the residual hoop surface compressive stresses after the IQ process:

- Formation of a much deeper martensitic surface layer at the very onset of the quench, prior to the start of the phase transformation in the part core; the deeper the martensitic shell or case, the more expansion of the material takes place in the part surface layer, and the higher the hoop surface compressive stresses around the still hot and plastic austenitic core.
- After the martensite transformation starts on the rod surface, there is substantial thermal shrinkage in the part core, resulting in pulling the part martensitic layer toward the core and inducing greater hoop compressive stresses.

The subsequent formation of martensite in the part core during intensive quenching ultimately results in the core swelling and diminishing the surface hoop compressive stresses. However, as seen from Fig. 5, after IQ, the residual surface hoop stresses are still compressive and much greater than that after oil quenching. This is in spite of the fact that the part core is martensitic (and therefore stronger) after IQ, while the core has a mixed structure after oil quenching. A phenomenon of developing high residual surface compressive stresses after IQ for through-hardened parts illustrated previously by

computer simulations is supported by numerous experimental data.

Along with uniformly fast cooling of the part shell, the key element of the IQ process is the interruption of the IQ at the proper time. The calculated time for interruption of IQ depends on part shape, part dimensions, type of steel, and ultimately the desired physical properties in accordance with the part specifications. For example, for parts made of through-hardened medium- and high-alloy steels, the quench is usually interrupted at the moment of time when surface compressive stresses are at their maximum value and the part hardened layer is at an optimum depth. A method for calculating an optimum interruption time during IQ is presented as follows.

After interruption of the intensive water quench, cooling then continues in air. The thermal energy coming from the still very hot part core tempers the martensitic surface layer, making it tougher and preventing possible cracking. On the other hand, for parts made of low- or medium-plain carbon steels having a low hardenability, or for parts made of carburized grades of steel, the interruption criterion is often calculated to provide the hardened shell or case as deep as possible.

A very commonly posed question regarding the IQ process is how it differs from induction case hardening (or shell hardening) methods. Like the IQ process, induction case hardening provides the part with residual compressive surface stresses and with a wear-resistant martensitic surface. However, unlike the IQ processes, induction case hardening strengthens only the part surface layer. The part core does not experience any phase transformations. If core

conditioning is required, the part must be through heated, quenched, and tempered prior to conducting induction case hardening. This is in contrast to the IQ methods that provide high compressive surface stresses and, at the same time, strengthen the core. Secondly, induction case hardening creates hardness and residual-stress profiles (from compressive at the surface to tensile below the surface) that are much steeper than those after IQ, because only a relatively thin part surface layer is austenitized by induction heating. Finally, the IQ process is interrupted when residual surface compressive stresses are at their maximum value, providing the part with an optimum hardened depth. The smoother hardness profile, the high residual compressive stresses, the properly toughened core, and the optimum depth of hardness after IQ processes result in better part performance characteristics—and in a single process.

In summary, the IQ process involves interrupted quenching in highly agitated water for through hardening. Both the intensity of cooling (the heat-extraction rate) and the cooling time are strictly defined depending on the part shape, dimensions, and type of steel and are determined by computer simulations. Due to greater cooling rates compared to conventional quenching, the IQ process provides a better material microstructure, deeper hardened layer, and high residual surface compressive stresses, resulting in stronger parts with better fatigue life and less energy consumed in processing. Due to the environmental benefits of IQ being a water-only quenchant, the IQ process facilitates part-by-part heat treatment operations within the manufacturing cell.

Heat Transfer during Quenching

As noted, two methods of IQ are used in practice. One is a three-step process (IQ-2) based on quenchant nucleate boiling during fast cooling, followed by slow cooling in air, and then convection cooling in the quench tank. The other method (IQ-3) is a one-step intensive cooling method based on direct convection cooling of the part surface. To better understand the fundamentals of IQ methods, it is helpful to briefly review the modes of heat transfer during quenching of steel parts in liquid quench media.

Heat Transfer during Conventional Quenching. When quenching parts in oil, polymer, or water, four consecutive modes of heat transfer take place: shock nucleate boiling, film boiling, nucleate boiling, and convection (Ref 3, Chapter 3). Figure 6 qualitatively presents the heat flux change from the part surface during quenching. The shock nucleate boiling process starts at the very beginning of part immersion into the quench bath. The heat flux from the hot part surface during this time period is very high, resulting in an almost instant initiation of the boiling process. Due to high heat flux during the shock boiling process, the rate of bubble formation is so great that, in a very

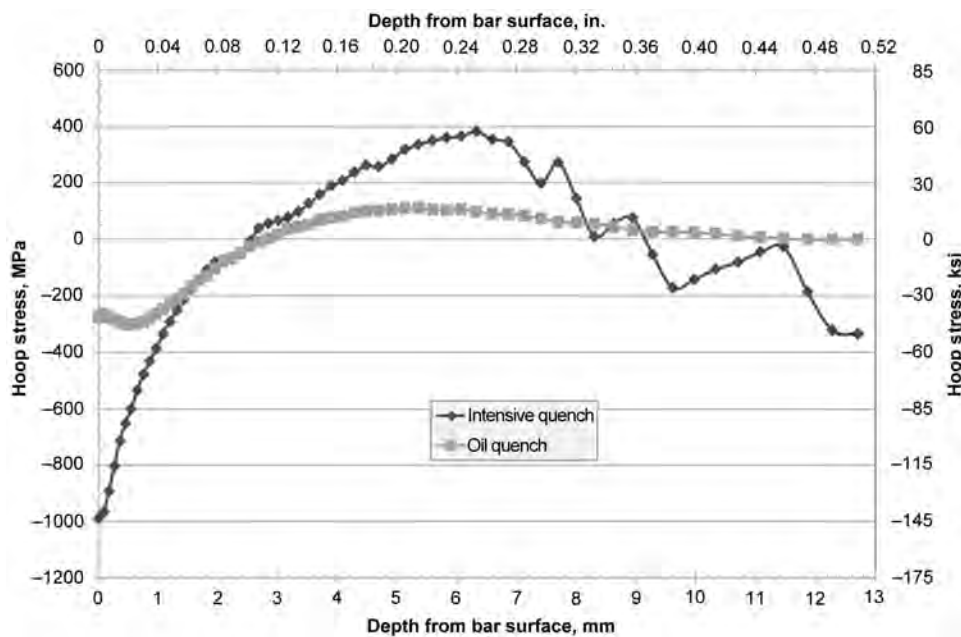

Fig. 5 Distribution of residual hoop stresses in 25 mm (1 in.) diameter rod made of 1045 steel after intensive quenching and after quenching in oil

short time period (usually approximately 0.1 s after the beginning of the quench), bubbles merge with each other to form a vapor blanket or film on the part surface. The heat flux from the part surface required for initiation of the film boiling mode of heat transfer is called the first critical heat flux density, q_{cr1} (Fig. 6). Note that the formation of the vapor blanket is a very unstable process and therefore uncontrollable. Prior to forming a vapor blanket throughout the entire part surface, areas of the film boiling move sporadically along the part surface, causing very nonuniform cooling. In addition, because the vapor blanket has low thermal conductivity, it creates a barrier for heat transfer from the hot part surface to the quenchant, resulting in sharp reduction of the heat flux from the part surface (Fig. 6) and a slowdown of the part cooling rate. The nonuniform and delayed cooling, in turn, may cause excessive part distortion and a spotty surface hardness, often called a slack quench.

Due to a gradual reduction of the part cooling rate, the temperature gradient throughout the part cross section decreases, resulting in the reduction of heat flux from the part surface. At some point, the heat flux on the surface of the part reaches a level at which it cannot support the film boiling process any longer. The vapor blanket starts to collapse, and the film boiling mode of heat transfer switches to the nucleate boiling mode. The heat flux at the part surface when the nucleate boiling process starts is called the second critical heat flux density, q_{cr2} (Fig. 6). Due to the absence of the vapor blanket (a thermal barrier) on the part surface during the nucleate boiling mode of heat transfer, the heat flux from the part surface starts to rise from q_{cr2} to its maximum value. Note that the nucleate boiling process is both a very stable and a very intensive mode of heat transfer. The average heat-transfer coefficient from the part surface during nucleate boiling is much greater than that during the nonuniform film boiling process. In the final stage of conventional quenching, as the heat flux from the part surface further reduces, the nucleate boiling process is replaced by convection heat transfer from the part surface to the liquid quenchant.

Heat Transfer during Batch Intensive Quenching (IQ-2 Process). Similar to conventional quenching, a shock boiling process initiates from the very beginning of the IQ-2 quench. However, in contrast to conventional quenching, the shock nucleate boiling process never transforms into the film boiling process. Thus, only two modes of heat transfer take place during the IQ-2 process: nucleate boiling followed by convection cooling. The film boiling process is fully eliminated in IQ water tanks due to the following measures: providing a vigorous (intensive) agitation of the quench bath, maintaining the water at close to ambient temperature, and using a small amount of water additives (usually mineral salts) that affect electrostatic conditions of the thin quenchant layer bearing against the part surface, resulting in an increase of

quenchant surface tension. All these factors increase the value of the first critical heat flux density, q_{cr1} , in the quench water. In other words, a greater heat flux from the part surface is required to bring the IQ-2 quench water to the saturated temperature needed to initiate the film boiling process at the part surface.

Another method for eliminating the film boiling process is to provide a redundant pressure above the surface of the quench bath. A detailed description of this approach is presented in Ref 3 (Chapter 8) and Ref 5. Raising the pressure in the quench chamber above the ambient pressure results in the rise of the water saturated temperature. This, in turn, causes an increase of the first critical heat flux density, q_{cr1} , which makes initiation of the film boiling process more difficult. For example, raising the pressure above the quench bath from ambient 0.1 to 0.2 MPa (1 to 2 bar) results in an increase of the water boiling temperature from 100 to 120 °C (212 to 248 °F) and an increase of q_{cr1} from 5.8 MW/m² to approximately 7.5 MW/m².

Due to the very high heat-transfer coefficient during nucleate boiling in water, the part surface temperature approaches the water boiling temperature very quickly. The part surface temperature stabilizes just above the quenchant boiling temperature for a certain time period (Fig. 7). Note that this period of cooling (characterized by a stabilized surface temperature) is absent when quenching parts in oil, due to a much smaller nucleate boiling heat-transfer coefficient in oil compared to that in IQ water tanks.

When the heat flux from the part surface drops further, the nucleate boiling process in water is replaced by the final mode of heat transfer: convection cooling (the same final cooling mode as in oil or polymer/water quenching).

Heat Transfer during Single-Part Intensive Quenching (IQ-3 Process). When implementing the IQ-3 process in high-velocity IQ systems, the water is flowing so fast along the part surface that the water does not have a chance to reach the boiling temperature. A so-called direct convection cooling takes place during the IQ-3 process. In this case, the

part surface temperature cools to the water temperature almost instantly (Fig. 7). The IQ-3 process provides the ultimate intensive cooling rate for steel parts during quenching that yields the highest as-quenched hardness and deepest quenched layer (versus conventional oil or polymer/water quenching). The IQ-3 process thus provides the maximum achievable improvement in material mechanical properties for a given alloy of steel in a given geometry.

Batch Intensive Quenching (IQ-2)

The three-step IQ method (referred to as IQ-2) is usually applied to batch quenching. As noted, the IQ-2 technique is a three-step procedure:

1. Fast cooling under quenchant nucleate boiling heat-transfer conditions on the part surface
2. Slow cooling in air
3. Convection cooling in the quench tank

During the first stage of cooling, martensite forms rapidly in the part surface layer, creating surface compressive stresses. The fast cooling is interrupted at an optimum time, when the surface compressive stresses reach their maximum value. At this point, the steel part is removed from the water quenchant. Usually, it happens at the end of the nucleate boiling stage of cooling (Fig. 7). In some cases (when the part is relatively thick), the optimum cooling time is longer than the duration of nucleate boiling, and the quench is interrupted when there is already convection heat transfer on the part surface. A method and example of calculating the optimum cooling time during the IQ-2 process is subsequently discussed in detail.

After interruption of the intensive stage of cooling, part cooling continues in air. During this second stage of IQ-2, the part surface layer, or shell, is self-tempered by the heat coming from the hot core. The part surface temperature increases while the part core decreases, resulting in equalization of the part temperature throughout its cross-sectional area. Also, in this second

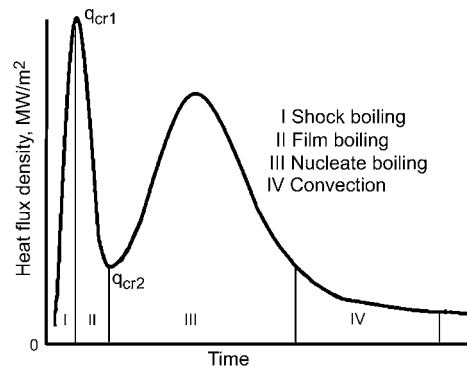

Fig. 6 Schematic of heat-transfer modes during quenching in liquid media. q_{cr1} , first critical heat flux density; q_{cr2} , second critical heat flux density. Source: Ref 3

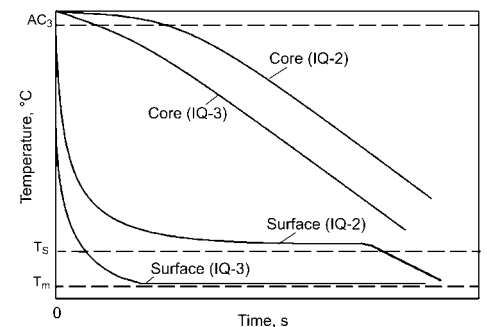

Fig. 7 Typical cooling curves at surface and core during intensive quenching processes (IQ-2 and IQ-3). AC_3 , austenitizing temperature; T_s , quenchant saturation temperature (100 °C, or 212 °F); T_m , water or water/salt solution temperature (usually 20 °C, or 68 °F)

stage, the part compressive surface stresses (developed as current compressive stresses in the first stage of cooling) are fixed. As a result of the self-tempering process, the martensitic surface layer strengthens (as toughened tempered martensite), eliminating possible part cracking during final stages of IQ-2 cooling.

In the third phase of the IQ-2 quench, the part is returned to the intensive quench tank for further convection cooling to complete the required phase transformations in the part surface layer. This third cooling step is needed to provide the maximum achievable improvement in material mechanical properties; because the first stage of cooling takes place mainly during the nucleate boiling mode of heat transfer, and even after cooling in air, the temperature of the part surface layer is still above the quenchant boiling temperature, which is above the martensite finish temperature for a majority of steels.

An analytical mathematical model of the nucleate boiling process was developed to determine the duration of this stage of IQ (Ref 3, Chapter 2). The model consists of a one-dimensional linear differential heat-conduction equation with a nonlinear boundary condition for a nucleate boiling process (Ref 5). An analytical solution of the aforementioned mathematical model for an infinite plate, infinite cylinder, and sphere is presented in Ref 5. The solution was obtained for so-called irregular and regular thermal conditions that take place during quenching of steel parts (Ref 3, 5). It was assumed that, at the moment of transition from the nucleate boiling process to convection, the heat flux densities for both modes of heat transfer are equal. In other words, the heat flux density from the part surface at the end of nucleate boiling is equal to the convective heat flux density at the beginning of convection heat transfer. The following equations for calculating the duration of the nucleate boiling process were obtained (Ref 3, Chapter 2):

$$\tau = \left[\Omega + f \ln \frac{\vartheta_I}{\vartheta_{II}} \right] \frac{K}{a} \quad \text{(Eq 1)}$$

where $\Omega = 0.48$, a parameter that determines the duration of the irregular portion of the thermal process (Ω is a relatively small value compared to τ) (Ref 3, Chapter 2); $f = 3.21$; K is a parameter (known as the Kondratjev form factor) that depends on the part shape and dimensions (Table 1), in m^2 ; and a is the steel thermal diffusivity, in m^2/s .

Values ϑ_I and ϑ_{II} are calculated from Eq 2 and 3 using an iterative technique:

$$\vartheta_I = \frac{1}{\beta} \left[\frac{2\lambda(\vartheta_0 - \vartheta_I)}{R} \right]^{0.3} \quad \text{(Eq 2)}$$

$$\vartheta_{II} = \frac{1}{\beta} [\alpha_{conv}(\vartheta_{II} + \vartheta_{th})]^{0.3} \quad \text{(Eq 3)}$$

where $\vartheta_0 = T_0 - T_s$; $\vartheta_{th} = T_s - T_m$; T_s is the part temperature, in $^{\circ}C$; T_m is the quenchant

temperature, in $^{\circ}C$; λ is the steel heat conductivity, in $W/m \cdot C$; R is the characteristic part dimension, in meters; α_{conv} is the convective heat-transfer coefficient in the quench tank, in $W/m^2 \cdot C$; and β is a parameter depending on the properties of the quenchant and vapors.

As an example, Table 1 presents the values for the Kondratjev form factor, K , for parts of simple shapes, while Table 2 includes data for steel thermal conductivity and thermal diffusivity, respectively. A convective heat-transfer coefficient, α_{conv} , in the quench tank can be calculated approximately using known experimental correlations between a nondimensional Nusselt number, Nu , and Reynolds number, Re , for a turbulent external flow (Ref 8), or it can be determined experimentally for a specific quench tank using special probes.

The results of calculations of the nucleate boiling process duration for different steel parts were confirmed by numerous experimental data (Ref 3, Chapter 2). The following example shows a procedure for calculating the duration of the nucleate boiling process for a cylindrical part that is 80 by 320 mm (3.15 by 12.6 in.)

diameter made of medium-alloy steel. The part is quenched from the initial temperature of $860^{\circ}C$ ($1580^{\circ}F$) in an IQ tank with a water flow velocity of 1.5 m/s (5.0 ft/s). First, a Kondratjev form factor, K , is calculated using the following equation from Table 1 for a finite cylinder:

$$K = \frac{1}{\frac{5.784}{R^2} + \frac{9.87}{Z^2}} = \frac{1}{\frac{5.784}{0.04^2} + \frac{9.87}{0.32^2}} = 269.4 \times 10^{-6} m^2$$

Secondly, the values of ϑ_I and ϑ_{II} are calculated. When determining parameter ϑ_I from Eq 2, the following average values for steel thermal diffusivity and thermal conductivity within the temperature range of 100 to $860^{\circ}C$ (212 to $1580^{\circ}F$) are used: $a = 5.36 \times 10^{-6} m^2/s$ and $\lambda = 22 W/m \cdot K$ (Table 2). Note that the thermal property values for supercooled austenite are applicable to a majority of steels.

Parameter β for water at $20^{\circ}C$ ($70^{\circ}F$) is equal to 3.45; $\vartheta_0 = T_0 - T_s = 860^{\circ}C - 100^{\circ}C = 760^{\circ}C$ ($1580^{\circ}F - 210^{\circ}F = 1370^{\circ}F$).

Table 1 Values for Kondratjev form factor, K , for parts of simple shapes (results of analytical calculations)

No.	Part shape	Coefficient K , m^2	$\frac{K}{V}$, m^{-1}	$K \frac{K}{V}$, m
1	Infinite plate of thickness L	$\frac{L^2}{\pi^2}$	$\frac{2}{L}$	$\frac{2L}{\pi^2}$
2	Infinite cylinder of radius R	$\frac{R^2}{5.784}$	$\frac{2}{R}$	0.346R
3	Square infinite prism with equal sides of L	$\frac{L^2}{2\pi^2}$	$\frac{4}{L}$	$\frac{2L}{\pi^2}$
4	Finite cylinder of radius R and height Z	$\frac{1}{\frac{5.784}{R^2} + \frac{\pi}{Z^2}}$	$\left(\frac{2}{R} + \frac{2}{Z} \right)$	$\frac{2RZ(R+Z)}{5.784Z^2 + \pi^2 R^2}$
5	Finite cylinder, $R = Z$	$\frac{R^2}{15.65}$	$\frac{4}{R}$	0.256R
6	Finite cylinder $2R = Z$	$\frac{R^2}{8.252}$	$\frac{3}{R}$	0.364R
7	Cube with side of L	$\frac{L^2}{3\pi^2}$	$\frac{6}{L}$	0.203L
8	Finite square plate with sides of L_1, L_2, L_3	$\frac{1}{\pi^2 \left(\frac{1}{L_1^2} + \frac{1}{L_2^2} + \frac{1}{L_3^2} \right)}$	$\frac{2(L_1L_2 + L_1L_3 + L_2L_3)}{L_1L_2L_3}$	$\frac{2(L_1L_2 + L_1L_3 + L_2L_3)L_1L_2L_3}{\pi^2(L_1^2L_2^2 + L_1^2L_3^2 + L_2^2L_3^2)}$
9	Sphere	$\frac{R^2}{\pi^2}$	$\frac{3}{R}$	0.304R

Table 2 Thermal conductivity, λ , and thermal diffusivity, a , of supercooled austenite versus temperature

Temperature		λ , $\frac{W}{mK}$	$\bar{\lambda}$, $\frac{W}{mK}$	a , $10^{-6} \frac{m^2}{s}$	\bar{a} , $10^{-6} \frac{m^2}{s}$
$^{\circ}C$	$^{\circ}F$				
100	212	17.5	17.5	4.55	4.55
200	390	18	17.75	4.63	4.59
300	570	19.6	18.55	4.70	4.625
400	750	21	19.25	4.95	4.75
500	930	23	20.25	5.34	4.95
600	1110	24.8	21.15	5.65	5.10
700	1290	26.3	21.90	5.83	5.19
800	1470	27.8	22.65	6.19	5.37
900	1650	29.3	23.4	6.55	5.55

Note: $\bar{\lambda}$ and \bar{a} at $500^{\circ}C$ ($930^{\circ}F$) (analogously at other temperatures) mean average values for the range of 100 to $500^{\circ}C$ (212 to $930^{\circ}F$)

Thus, the equation for determining ϑ_I is the following:

$$\vartheta_I = \frac{1}{\beta} \left[\frac{2\lambda(\vartheta_0 - \vartheta_I)}{R} \right]^{0.3} \\ = \frac{1}{3.45} \left[\frac{2 \times 22(760 - \vartheta_I)}{0.04} \right]^{0.3}$$

From solving this equation, the value of ϑ_I is equal to 17.2 °C (63.0 °F). When determining parameter ϑ_{II} from Eq 3, the following values for the convective heat-transfer coefficient and parameter ϑ_{uh} are used: $\alpha_{conv} = 5000 \text{ W/m}^2 \text{ °C}$; $\vartheta_{uh} = T_s - T_m = 100 \text{ °C} - 20 \text{ °C} = 80 \text{ °C}$ (210 °F - 70 °F = 140 °F). Thus, the equation for determining ϑ_{II} is the following:

$$\vartheta_{II} = \frac{1}{\beta} [\alpha_{conv}(\vartheta_{II} + \vartheta_{uh})]^{0.3} \\ = \frac{1}{3.45} [5000 \times (\vartheta_{II} + 80)]^{0.3}$$

From solving this equation, the value of ϑ_{II} is equal to 14.6 °C (58.3 °F). From Eq 1, the duration of the transient nucleate boiling process for the part considered is:

$$\tau = \left[\Omega + f \ln \frac{\vartheta_I}{\vartheta_{II}} \right] \frac{K}{a} \\ = \left[0.48 + 3.21 \ln \frac{17.2 \text{ °C}}{14.6 \text{ °C}} \right] \frac{269.4 \times 10^{-6} \text{ m}^2}{5.36 \times 10^{-6} \text{ m}^2/\text{s}} \approx 51 \text{ s}$$

Single-Part IQ Process (IQ-3)

The one-step IQ method (referred to as IQ-3) is usually employed for single-part quenching operations. In contrast to the multistep cooling rates of the IQ-2 process, the IQ-3 technique involves intense one-step cooling such that heat transfer on the part surface is simply convection (direct convection cooling). As noted, when the IQ-3 process is applied, part surface cooling is so fast that both film boiling and nucleate boiling are completely avoided, and the basic heat-transfer mode on the part surface is simply convection.

The part surface temperature cools almost instantaneously to the water temperature, usually close to ambient temperature or approximately 20 °C (68 °F) during the IQ-3 process (Fig. 7). Because the water temperature is below the martensite finish temperature (M_f) for a majority of steels, the IQ-3 process creates the conditions for developing the maximum possible temperature gradient throughout the part being quenched and for developing a 100% martensitic structure in the part surface layer. As a consequence, with the IQ-3 process, the maximum achievable residual surface compressive stresses and the highest physical properties for the part are attained (for a given hardenability of steel alloy and for a given part geometry). This is also why IQ-3 can often allow the use of a less expensive, lower-alloy

steel and provide equal or better part performance (e.g., AISI 1045 substituted for AISI 4140 alloy, or AISI 1020 substituted for case-carburized AISI 8620 alloy).

In the IQ-3 method, intensive cooling is continuous and uniform over the entire part surface until compressive stresses on the part surface reach their maximum value. Note that the optimal hardened depth depends on the part geometry and type of steel, but the optimal hardened depth corresponds to the maximum surface compressive stresses. These maximized compressive surface stresses will be diminished if the core of the part is cooled further, for example, to the quenchant temperature. Therefore, the second key element of the IQ-3 process is to interrupt intensive cooling at the proper time—when compressive surface stresses are at their maximum value and to the optimum depth.

When designing an IQ-3 process, two issues should be resolved: what convective heat-transfer coefficient (HTC) on the part surface should be provided to eliminate the possibility of any type of boiling, for uniform direct convection cooling, and when the IQ process should be interrupted to provide maximum residual surface compressive stresses. The required HTC is determined by using Eq 1 to 3, assuming that the duration of the nucleate boiling process, τ , is equal to zero (hence the parameter Ω in Eq 1 is also equal to zero). With this assumption, the required convective HTC can be calculated from the following equation:

$$\alpha_{conv} \geq \frac{2\lambda(\vartheta_0 - \vartheta_I)}{R(\vartheta_I + \vartheta_{uh})} \quad (\text{Eq 4})$$

The optimum duration of the IQ-3 process for maximum residual surface compressive stresses can be determined from the following equation (Ref 3, Chapter 10):

$$\tau = \left[\frac{kBi_V}{2.095 + 3.867Bi_V} + \ln \left(\frac{T_0 - T_m}{T - T_m} \right) \right] \frac{K}{aKn} \quad (\text{Eq 5})$$

where k is a parameter equal to 1 for an infinite plate, 2 for an infinite cylinder, and 3 for a sphere; T_0 is the initial part temperature prior to quenching, in °C; T_m is the water temperature, in °C; T is the part core temperature at a time when surface compressive stresses are at their maximum value (this temperature depends on the part shape and usually is in the range of 350 to 450 °C, or 660 to 840 °F, as shown by numerous calculations) (Ref 3, Chapter 7); K is the Kondratjev form factor (Table 1); Kn is the nondimensional parameter (known as the Kondratjev number); and Bi_V is the generalized Biot number.

A generalized Biot number, Bi_V , is calculated by the following formula:

$$Bi_V = \frac{\alpha_{conv}}{\lambda} K \frac{S}{V} \quad (\text{Eq 6})$$

where S is the surface area of the part, in m^2 ; and V is the volume of the part, in m^3 . A generalized Biot number, Bi_V , is a nondimensional parameter that is similar to a conventional Biot number used for analyzing conduction heat transfer (Ref 8). The difference is that a conventional Biot number is applied to bodies of simple shapes (an infinite plate, infinite cylinder, and sphere), while a generalized Biot number is used for parts of a complex geometry. The expression $K \frac{S}{V}$ in Eq 6 represents a characteristic dimension for parts of complex shapes. Note that a characteristic part dimension used for calculating a conventional Biot number is a radius for an infinite cylinder or sphere, or a half-thickness for an infinite plate.

The Kondratjev number, Kn , is calculated using the following equation:

$$Kn = \frac{Bi_V}{(Bi_V^2 + 1.437Bi_V + 1)^{0.5}} \quad (\text{Eq 7})$$

A nondimensional parameter, the Kondratjev number, Kn , characterizes the intensity of cooling and varies in the range of 0 to 1 (for IQ processes, $Kn > 0.8$) (Ref 3, Chapter 10). The following example shows a procedure for calculating the minimum convective HTC required for implementing the IQ-3 process and an optimum cooling time for the same part as considered earlier: a cylinder of 80 by 320 mm (3.15 by 12.6 in.) diameter made of medium-alloy steel. First, a minimum HTC that provides a direct convection condition required by the IQ-3 process is calculated using Eq 4:

$$\alpha_{conv} \geq \frac{2\lambda(\vartheta_0 - \vartheta_I)}{R(\vartheta_I + \vartheta_{uh})} = \frac{2 \times 22(760 - 17.2)}{0.04(17.2 + 80)} \\ = 8406 \frac{\text{W}}{\text{m}^2\text{K}}$$

Then, a generalized Biot number, Bi_V , and a Kondratjev number, Kn , are calculated using Eq 6 and 7:

$$Bi_V = \frac{8406 \text{ W/m}^2\text{K}}{22 \text{ W/mK}} \times 269.4 \times 10^{-6} \text{ m}^2 \\ \times \frac{2 \times 3.14 \times 0.04 \times 0.32 \text{ m}^2 + 2 \times 3.14 \times 0.04^2 \text{ m}^2}{3.14 \times 0.04^2 \times 0.32 \text{ m}^3} \\ = 5.79 \\ Kn = \frac{5.79}{(5.79^2 + 1.437 \times 5.79 + 1)^{0.5}} = 0.885$$

Finally, the optimum cooling time is calculated by using Eq 5, taking into account that, for cylindrical parts, maximum residual surface compressive stresses are observed when the part core temperature is 450 °C (840 °F) (Ref 3):

$$\tau = \left[\frac{2 \times 5.79}{2.095 + 3.867 \times 5.79} + \ln \frac{860 - 20}{450 - 20} \right] \\ \frac{269.4 \times 10^{-6} \text{ m}^2}{5.36 \times 10^{-6} \text{ m}^2/\text{s} \times 0.885} \approx 65 \text{ s}$$

Improvement of Steel Microstructure, Mechanical Properties, and Stress Conditions

The significantly higher quench-cooling rates used in the IQ processes versus conventional quenching methods results in a different microstructure in the parts after intensive quenching than after oil quenching. Depending on the hardenability of the material, steels subjected to IQ are harder, to a deeper level, and have a finer structure than conventionally quenched parts of the same alloy. Over the years, numerous studies of mechanical properties of intensively quenched test samples and actual parts have been conducted (Ref 2, 4, 9–20). Some of the data from the referenced studies are presented subsequently. The IQ data were compared to the same test specimens and parts quenched in oil. In all instances, the oil-quenched parts and the IQ parts were made from the same steel heat and were tempered to the same surface hardness. The IQ parts have shown superior mechanical properties. The data clearly demonstrate that the IQ process significantly improves steel mechanical properties and parts performance characteristics versus traditional oil quenching.

Through-Hardening Steels. Table 3 presents data on mechanical properties for some plain carbon and through-hardened alloy steels. Large and small cylindrical test samples with diameters ranging from 6 to 50 mm (0.25 to 2.0 in.) were used. All test samples were heated to their standard austenitizing temperature, depending on the type of steel. The samples were tempered after quenching at temperatures ranging from 370 to 500 °C (700 to 925 °F). The following steel properties were measured: tensile strength, yield strength, elongation, reduction in area, and impact strength. A detailed description of the test procedures applied is presented in Ref 9 and 16.

As an example, Fig. 8 illustrates the significant difference in microstructure for 19 mm (0.75 in.) test bars made of AISI 1045 steel after IQ and after oil quenching. The significantly finer microstructure obtained after IQ, in turn, yields better mechanical properties (Table 3) than the comparable oil-quenched steels. Note that the higher hardness of the IQ steel does not come at the expense of the ductility; in fact, the ductility is usually somewhat higher for the IQ material. This means that the majority of the IQ samples were stronger and, at the same time, more ductile when compared to the oil-quenched samples.

Generally, the IQ steels have a higher hardness to a greater depth versus the oil-quenched steels, independent of the section size of the specimen. The rapid cooling from the IQ provides a higher strength level and also better impact resistance, even at the higher strength levels achieved with IQ.

Improvement of Strength and Ductility. Intensive quenching can result in a simultaneous improvement of both material strength and ductility, an effect sometimes referred to as superstrengthening. It was first reported in Ref 21. The mechanism of the additional strengthening can be explained by the following. A residual supercooled austenite in the part surface layer plastically distorts when being subjected to high compression from the firm martensite plates that appear in the austenite. This results in the formation of an extremely high density of dislocations in the austenite that improve the material mechanical properties after quenching. The higher the cooling rate

within the martensite formation range, the greater the compression from the martensite plates and the greater the density of the dislocations. During very rapid cooling, there is not enough time for the dislocations to accumulate in the grain boundaries and to form nuclei of future microcracks. The dislocations are “frozen” in the material. Thus, the rapidly forming martensite plates act like microscopic “blacksmiths;” under conditions of high current stress during intensive cooling, the expanding plates of martensite arise explosively, deforming the austenite and creating extremely high dislocation densities. The superstrengthening effect is similar to work hardening that takes place in

Table 3 Mechanical properties improvement for plain carbon and alloy through-hardened steels

Steel	Bar diameter		Quench(a)	Core hardness, HRC	Material strength					
					Ultimate strength		Yield strength		Impact strength at 22 °C (72 °F)	
					MPa	ksi	MPa	ksi	J	ft·lbf
1038	30	1.2	IQ	26	842	123	622	90	84	62
			Oil	23	807	117	532	77	38	28
1045	19	0.75	IQ	37	1191	173	1125	163	54	40
			Oil	32	980	142	766	111	53	39
1045	50	2.0	IQ	28	891	129	704	102	34	25
			Oil	27	880	128	626	91	31	23
1060	19	0.75	IQ	44	1465	212	1377	200	26	19
			Oil	40	1227	178	966	140	27	20
5160	19	0.75	IQ	48	1728	251	1584	230	22	16
			Oil	47	1592	231	1472	213	22	16
5160	38	1.5	IQ	48	1886	273	1499	217	9	7
			Oil	48	1623	235	1292	187	9	7
4140	19	0.75	IQ	48	1506	218	1181	171	40	30
			Oil	45	1350	196	1125	163	22	16
4140	50	2.0	IQ	44	1447	210	1072	155	20	15
			Oil	42	1329	193	1004	146	19	14
4130	22	0.87	IQ	35	1084	157	984	143	95	70
			Oil	30	925	134	809	117	125	92
40X (5140)(b)	50	2.0	IQ	28	860	125	695	101	168	124
			Oil	20	780	113	575	83	113	83
35XM (4130)(b)	50	2.0	IQ	30	970	141	820	119	150	111
			Oil	30	960	139	775	112	54	40
25X1M (4118)(b)	50	2.0	IQ	30	920	133	820	119	170	125
			Oil	20	755	109	630	91	70	52

(a) IQ, intensive quench. (b) Russian steels with AISI equivalent in parentheses

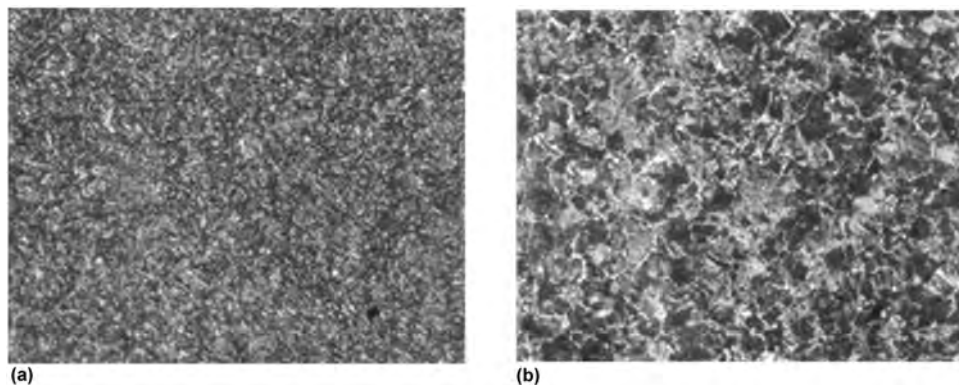

Fig. 8 Microstructure for 19 mm (0.75 in.) diameter rod made of 1045 steel after (a) intensive quenching and (b) oil quenching. Original magnification: 250 \times . Source: Ref 16

low-temperature thermomechanical treatment of steel. A detailed description of the material superstrengthening effect can be found in Ref 3, Chapter 9.

Carburized Steels. The following parameters were evaluated for samples made of carburized grades of steel (Ref 16): effective case depth (ECD), microhardness distribution from surface to core, material microstructure, and residual surface compressive stresses. Test samples of 30 mm (1.18 in.) diameter were made of plain carbon AISI 1018 steel and the following alloy steels: AISI 4320, 5120, and 8620. All samples were carburized with the same cycle: 927 °C (1700 °F) for 5 h at 0.9% C potential. After the carburization cycle was completed, the samples were furnace cooled under a protective atmosphere. All alloy steel samples were then reheated to 843 °C (1550 °F) and quenched in oil, while AISI 1018 steel samples were reheated to 860 °C (1580 °F) and quenched in the IQ water tank or in the single-part, high-velocity IQ system. All samples were tempered at 204 °C (400 °F) for 2 h.

Figure 9 presents the hardness distribution for the processed test samples over the entire diameter and for the 2.5 mm (0.1 in.) surface layer. As seen from the graph, after identical 5 h carburizing cycles, the ECD at 50 HRC for the IQ samples was the same or deeper compared to the alloy steel samples quenched in oil. This is because IQ needs less carbon in the case gradient to reach 50 HRC.

Residual-Stress Conditions. The IQ processes provides high residual surface compressive stresses for parts made of through-

hardened steels. This is in contrast to conventional quench methods that provide neutral or tensile residual stresses for these materials. As mentioned earlier, high residual surface compressive stresses after the IQ process are due to a high-temperature gradient throughout the part cross section at a time when martensite starts forming in the part surface layer (Fig. 3) and establishes high current compressive stresses. As an example, Fig. 10 and 11 present experimental data on residual surface compressive stress profiles for cold work punches made of shock-resisting S5 steel (Ref 11) and for a bearing roller made of AISI 52100 steel (Ref 16). In both cases, residual stresses were measured by the x-ray diffraction method. As seen from Fig. 10, residual surface stresses for the punch after quenching in oil are tensile of approximately 200 MPa (29 ksi), while these same stresses are compressive after IQ. The residual surface compressive stresses for the punch are in the range of -500 to -950 MPa (-72 to -138 ksi). The surface stresses are still compressive at a depth of more than 0.5 mm (0.020 in.) from the punch surface. Note that the presence of residual surface compressive stresses changes the failure mode for the IQ punches to wear from the oil-quenched punches chipping, and it improves punch service life by at least 100%. This means the user obtains at least twice as many holes punched from IQ punches versus oil-quenched punches made of the same material.

The residual surface compressive stresses for the bearing roller (Fig. 11) reach the maximum value of -230 MPa (-33.3 ksi) when quenching in the IQ water tank and -900 MPa

(-130 ksi) when quenching in the single-part processing IQ system. These residual stresses extend under the surface to a depth of 2.5 to 2.9 mm (0.10 to 0.11 in.). Note that the single-part quenching IQ process provides higher residual surface stresses compared to the test sample quenched intensively in the IQ water tank. This is because the single-part IQ method provides greater cooling rates compared to quenching in an IQ water tank.

Figure 12 shows a distribution of the residual surface compressive stresses for test samples made of carburized AISI 1018 and 8620 steels. Test samples made of 1018 steel were quenched in the IQ water tank and in the single-part processing IQ system. The results show the significantly improved residual surface stress conditions for both IQ test samples compared to the oil-quenched specimen. Figure 13 presents a residual surface stress profile for the automotive pinions made of carburized AISI 8620 steel after IQ in the IQ water tank and conventional quenching in oil. The residual stresses are compressive for both quench methods. However, as seen from the figure, the residual surface compressive stresses are approximately two times greater when applying the IQ process.

Table 4 presents values for the surface residual compressive stresses for various actual parts and test samples. As seen from the figures and Table 4, the values of surface residual stresses of up to -900 MPa (-130 psi) can be achieved when quenching parts intensively in water or water/salt solutions.

Summarizing the previous information, the following conclusions can be made:

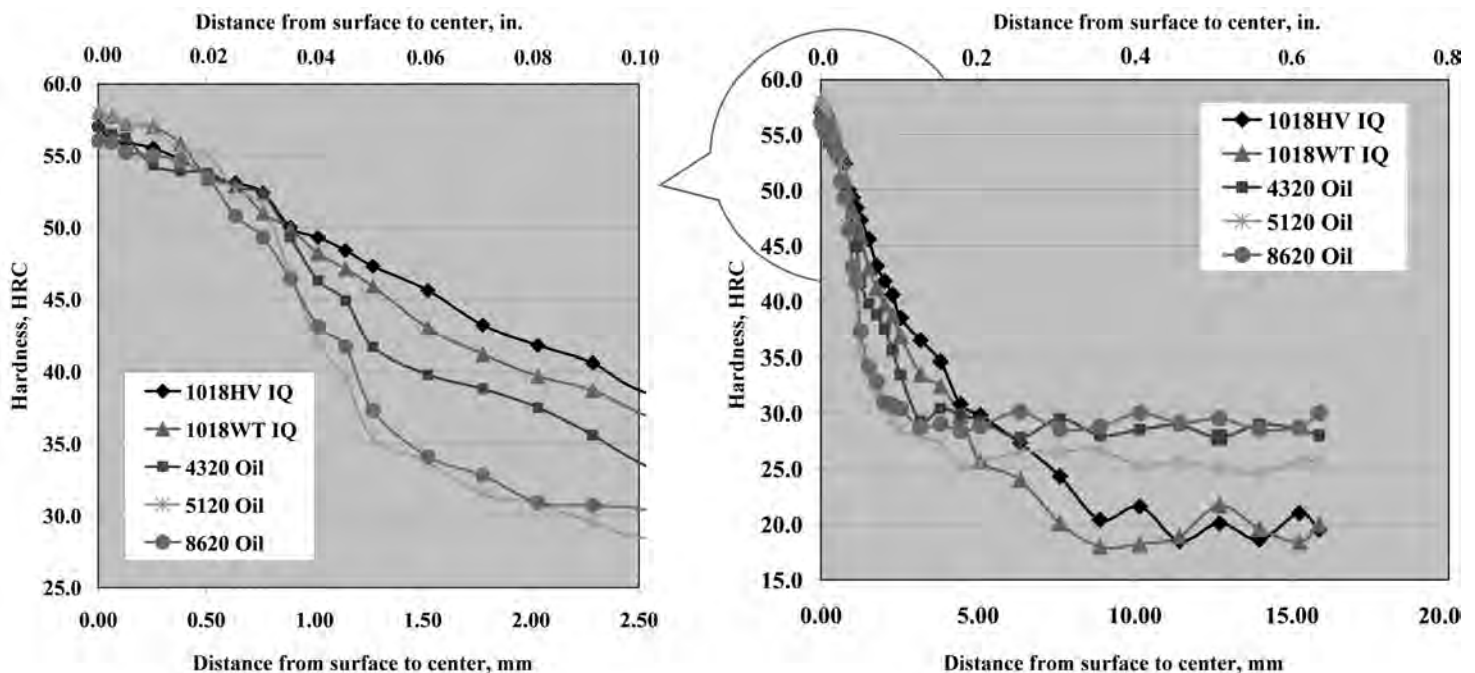

Fig. 9 Hardness distribution for test samples made of AISI 1018, 4320, 5120, and 8620 steels. IQ, intensive quenching. Source: Ref 16

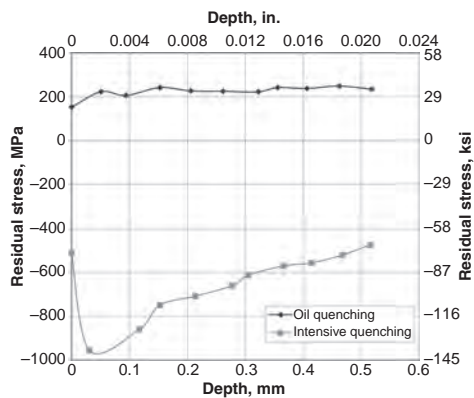

Fig. 10 Residual surface stresses for S5 steel punch. Source: Ref 11

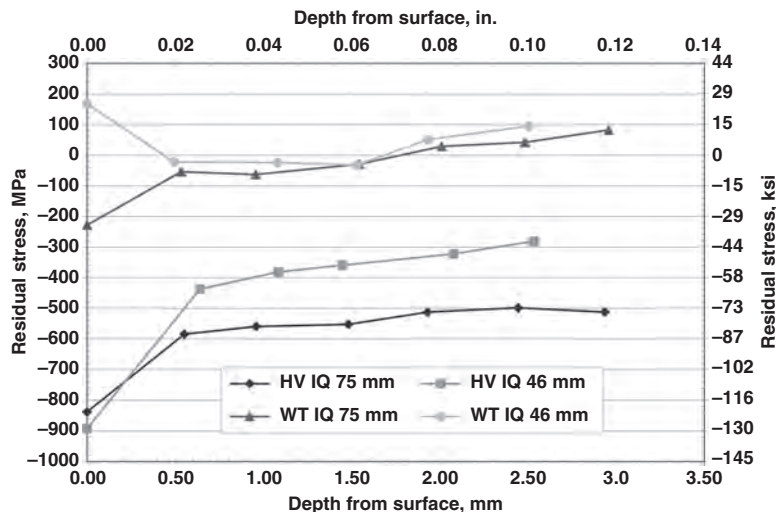

Fig. 11 Residual surface stresses for 52100 steel bearing roller. Source: Ref 16

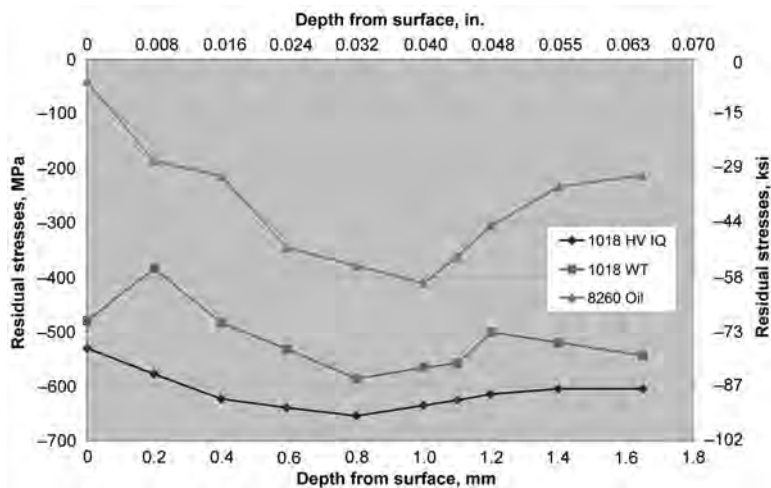

Fig. 12 Residual surface stresses for 32 mm (1.3 in.) diameter bars made of 1018 and 8620 steel. IQ, intensive quenching. Source: Ref 16

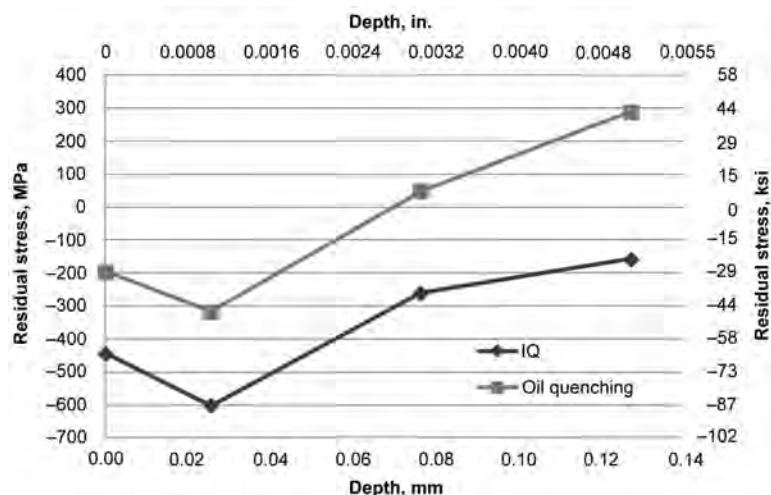

Fig. 13 Residual surface stresses for automotive pinion made of 1018 and 8620 steels. IQ, intensive quenching

Table 4 Residual surface compressive stresses after intensive quenching and tempering

Part	Residual surface compressive stresses	
	MPa	psi
52100 steel bearing ring, 22 cm (8.5 in.) diameter	-136	-20
52100 steel bearing roller, 7.5 cm (3 in.) diameter	-840	-122
52100 steel bearing roller, 4.5 cm (1.8 in.) diameter	-900	-130
4140 steel kingpin, 4.5 cm (1.8 in.) diameter	-563	-82
S5 steel punch, 4.0 cm (1.5 in.) diameter	-750	-109
5160 steel torsion bar sample, 3.5 cm (1.4 in.) diameter	-311	-45
1045 steel cylindrical part, 3.5 cm (1.5 in.) diameter	-430	-62
1547 cylindrical part, 7.29 cm (2.87 in.) diameter	-626	-91
1547 cylindrical part, 5.0 cm (2 in.) diameter	-515	-75
Pyrowear-53 carburized gear:		
Oil quench	-350	-51
Intensive quench	-800	-116

- For a given type of steel of the same section size, the IQ steel specimens generally develop higher strength and, at the same time, higher ductility than the steel samples quenched in oil. A superstrengthening of material takes place during IQ.
- The impact properties obtained from IQ steels are generally superior to the impact properties from oil-quenched steels.
- The IQ process provides high residual surface stresses for parts made of through-hardened steels, even when the part core is fully hardened.
- For carburized grades of steel, the IQ process provides a higher ECD with greater and deeper residual surface compressive stresses.
- The IQ specimens made of plain carbon carburized steel showed deeper ECDs, with higher residual surface compressive stresses, than those specimens made of alloy carburized grades that were quenched in oil.

IQ Process and Part Distortion

The two major phenomena causing part distortion during conventional quenching are thermally induced deformation and martensite phase-transformation size change (swelling). These same reasons for part distortion are also present in the IQ process. However, an absolute value of predictable part distortion after IQ is usually less compared to conventional quenching in oil. The major reasons for this include:

- More uniform cooling during IQ, due to the absence of the film boiling process and to a more uniform heat-extraction rate from the part surface in the quench bath, reduces non-predictable distortion.
- Phase transformation in the parts takes place under different thermal conditions during the IQ process.

As known, more uniform cooling during quenching results in less part distortion. However, in many cases, even with a uniform heat-extraction rate throughout the entire part surface area, the part will distort due to its shape: thin sections of the part cool faster compared to thicker sections. This causes nonuniform thermal contraction followed by nonuniform formation of the martensitic shell. The IQ process usually reduces part distortion in such cases compared to conventional quenching in oil. As an example, consider distortion for a 25 by 250 mm (1 by 10 in.) diameter keyway shaft with a 6.35 by 6.35 mm (0.25 by 0.25 in.) keyway made of AISI 1045 steel. Reference 22 presents the results of computer simulations of the distortion for the keyway shaft, as well as actual experimental shaft distortion measurements after quenching in oil and after IQ in the IQ water tank or in the single-part high-velocity IQ system. To simplify the evaluation of the shaft distortion, only one parameter characterizing the part deformation was used: the shaft bow/flatness (Fig. 14).

The results of calculations show the following dynamics of keyway shaft distortion during IQ. At the very beginning of the quench (prior to the start of martensite transformation on the part surface), the shaft is bowing toward the keyway due to the development of current tensile surface stresses at the keyway corners, which experience greater thermal contraction compared to the rest of the shaft. Note that at the initiation of the quench, the hot shaft core is still at the austenitizing temperature and very low in strength. Therefore, the material in the shaft core is plastic and does not resist bowing

of the shaft caused by thermal shrinking at the surface in the keyway corners.

The direction of the shaft bowing changes after the material at the keyway corners reaches the martensite start temperature. The formation of martensite causes the steel to expand, resulting in the development of current surface compressive stresses. These surface compressive stresses start to bend the shaft in the opposite direction (against the keyway). The reverse bending continues until the surface compressive stresses reach their maximum value. At this point, the thermally induced bow practically disappears. Continued phase transformation in the shaft causes swelling in the part core that partially cancels the compressive surface stresses. As a result, the shaft bows a little bit back toward the keyway. A calculated value of the final shaft out-of-straightness after IQ is 98 μm (Ref 22).

During conventional quenching in oil, the keyway shaft also bows first toward the keyway due to thermal shrinkage of the material prior to the start of martensite transformation. Similar to IQ, after martensite begins to form on the part surface, the current surface compressive stresses created by material expansion start to reverse the bowing of the shaft. However, because these compressive stresses are much smaller compared to those formed during the IQ process, they cannot fully compensate for the thermally induced bow. After phase transformation is completed throughout the shaft cross section, the part core swells, fully cancelling compressive stresses on the part surface, causing a reversal of the bowing toward the keyway and increasing the final shaft distortion. So, at the end of oil quenching, in contrast to IQ, the keyway shaft is bent toward the keyway (Fig. 14). A calculated value of the final shaft out-of-straightness after quenching in oil is 871 μm (Ref 22).

A good agreement between the results of calculations and the experimental data (Ref 22) supports that the dynamics of keyway shaft distortion predicted by the computer simulation and the dynamics described previously in the actual parts are correct. Table 5 presents experimental data (Ref 4) on keyway shaft final distortion after the IQ processes and after conventional oil quenching. As seen from Table 5, both IQ methods provide much less keyway shaft final distortion compared to conventional quenching in oil. The data from Table 5 also show that the single-part quenching IQ-3 process produces less part distortion compared to the batch IQ-2 method. For symmetrical parts, the distortion can be as low as 50 μm . For example, distortion for drive shafts made of

alloy carburized steel and having a diameter of approximately 40 mm (1.6 in.) with a length of 385 mm (15.2 in.) was only 50 to 70 μm after quenching one-by-one in the IQ system.

It is important to note that at the end of quenching, IQ parts usually have greater dimensions compared to identical oil-quenched parts. For example, computer simulations (Ref 23) conducted for a spur gear having 40 teeth, a module of 2.54, and a face width of 6.35 mm (0.25 in.) show that the IQ gears grew approximately 0.05 mm (0.002 in.) more in the radial direction compared to oil-quenched gears (0.18 versus 0.13 mm, or 0.007 versus 0.005 in., respectively). The major reason for this is differences in stress states and their distributions during the IQ process and conventional oil quenching. In accordance with computer simulations and actual x-ray measurements, the magnitude of residual surface hoop stresses after IQ were approximately twice the value of hoop compression from oil quenching. While the parts after IQ may swell more, this distortion in part dimensional growth is predictable and repeatable, and it can be managed by adjusting the pre-heat green size of the part. The IQ process provides repeatable distortion because more uniform cooling fully eliminates the nonpredictable and nonuniform film boiling process. Unlike random, nonuniform distortion, predictable distortion is really only expected size change, and it is usually manageable for the part maker. Therefore, an adjustment of the part green sizes can address the predictable dimensional changes resulting from the IQ process.

Design of Production IQ Systems

Currently there are two general types of IQ equipment. The first one is designed for implementing the IQ-2 quenching processes (either for batch operations or for continuous operations). These batch IQ systems are similar to those used with conventional oil quenching or batch polymer water quenching methods. The second type of IQ system is designed for implementing single-part, high-velocity IQ-3 processes. The following three key elements of the IQ processes will dictate the design of the applicable IQ equipment:

- Intensive quenching uses highly agitated plain water or low-concentration water/mineral salt solutions as a quenchant.
- With any form of IQ, it is necessary to provide a proper high heat-extraction rate uniformly over the entire part surface area, to

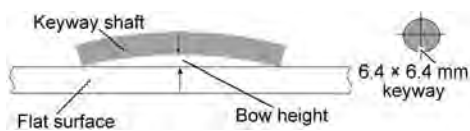

Fig. 14 Distortion of keyway shaft during intensive quenching and quenching in oil

Table 5 Keyway shaft distortion

Single-part oil quenching		Batch oil quenching		Single-part intensive quenching	
mm	in.	mm	in.	mm	in.
0.20–0.36	0.008 – 0.014	0.25–0.51	0.010–0.020	0.08–0.12	0.003–0.005

develop a uniform, strong martensitic shell and residual surface compressive stresses.

- It is necessary to interrupt IQ after a certain dwell time, the time when the current residual surface compressive stresses are at their maximum value and their optimum depth in the part.

In batch-type IQ systems, multiple parts are uniformly heated through to the austenitizing temperature, typically in a furnace in alloy baskets. For IQ, the baskets are transferred from the furnace hot zone to the IQ water quench tank. Any type of batch furnace (atmosphere, fluidized bed, or salt bath) can be used when implementing the IQ-2 process. The IQ tank can be separated from the furnace, or it can be a part of an integral quench furnace. Both of these designs are considered as follows.

Figure 15 shows an example of a production system with a stand-alone IQ water tank. The IQ system consists of an atmosphere furnace (on the left) having a work zone of 91 by 91 by 122 cm (36 by 36 by 48 in.) and an IQ water tank (on the right) of 22.7 m³ (6000 gal). A standard transfer cart is used to move the load from the furnace to the quench tank. Transfer-time considerations are no different than good conventional quenching practices; the parts should be uniformly austenitic when they enter the quench. The mild steel IQ tank is equipped with four propellers that are rotated by four 10 hp motors. Note that a similar oil quench tank would be equipped with only two propellers rotated by 5 hp motors. The IQ tank uses plain water with a low concentration of sodium nitrite salts as the quenchant. The quenchant flow velocity in the tank is approximately 1.5 to 1.6 m/s (5 to 5.2 ft/s)

as it passes over the parts. An air-cooling system maintains the quench water within the required temperature range. The maximum load mass per heat is approximately 900 kg (2000 lb).

Figure 16 presents a picture of a 91 by 91 by 183 cm (36 by 36 by 72 in.) production integral quench furnace equipped with a 39.7 m³ (10,500 gal) IQ water tank built by AFC-Holcroft Company of Wixom, Michigan, USA, and installed at the Euclid Heat Treating Co. of Cleveland, Ohio, USA. The IQ tank is equipped with four propellers that are rotated by four motors providing a total recirculation of approximately 5.67 m³/s (90,000 gal/min). The approximate velocity of the quenchant in the tank is 2 m/s (7 ft/s) past the parts. Internal directional vanes and baffles provide a uniform quenchant flow velocity through the workload. The quenching chamber is equipped with a unique lifting mechanism that provides accelerated vertical motion into and out of the quench tank. Minimizing this motion time is very important for accurately implementing the intensive cooling dwell time for IQ recipes.

The following major issues should be addressed when designing batch-type IQ systems:

- Provide a uniform water flow velocity distribution throughout the cross section of the quench tank working zone by installing a proper set of baffles at the bottom of the tank and straightening vanes in the propeller draft tubes. A variation of the water flow velocity through the quench tank work zone should be within approximately 10%.
- Provide a water flow velocity of at least 1.5 m/s (5 ft/s).

- To maintain the water temperature in the IQ tank not exceeding 25 °C (77 °F), the IQ water tank should be equipped with an air-cooling system or a chiller, or with a combined system including an air-cooling unit and a chiller.
- The propeller assembly should minimize air entrainment into the quench tank. (The presence of air bubbles in the water reduces the heat-extraction rate from the part being quenched and may affect the uniformity of cooling.)
- The propeller size and location (a depth under the water and a distance from the tank walls) and the parameters of the draft tubes should be selected to minimize the total system head resistance.

Continuous-Type IQ Systems. Figure 17 presents a sketch of an industrial continuous heat treating line using the IQ-2 quenching process (Ref 3, Chapter 10). The heat treating line includes the following major components: continuous furnace, quench tank equipped with a chute, pump, quenchant cooling system, variable-speed conveyor, washing unit, conveyor that moves the parts through the washing unit, and continuous tempering furnace equipped with its own conveyor.

In the first step of quenching, the parts are intensively cooled, first while falling through the chute and then while lying on the quench tank conveyor. The quench tank conveyor is of variable speed and moves the parts through the IQ tank to the second conveyor that is installed above the tank. During the subsequent cooling in air (while the parts are moving to the washing unit), the temperature of the parts equalizes through their cross



Fig. 15 Batch-type intensive quenching (IQ) system with stand-alone IQ water tank. Courtesy, Akron Steel Heat Treating Co.



Fig. 16 Integral quench atmosphere furnace equipped with intensive quenching water tank. Source: Reprinted from Ref 3 with permission of ASTM International

section, and a self-tempering process takes place, resulting in tempering a martensitic shell on the part. Then, the parts are intensively cooled again in the unheated washing chamber until they reach ambient temperature. Thus, the unheated washing chamber provides both the part cleaning (there is no oil to remove or skim from the washwater) and the final step of the IQ-2 process. After washing, the parts are transferred to the tempering furnace. The speeds of the quench tank conveyer and washing unit conveyer are varied and controlled in accordance with the part-specific IQ cooling recipes.

Single-Part-Processing IQ Systems. When performing the IQ-3 process, the parts are usually quenched one by one with very high-velocity water flow or jet impingement. Figure 18 presents the layout of a typical IQ system for single-part processing.

In practice, any through-heating source may be used—induction, atmosphere, and so on. The IQ-3 quench sequence is as follows. With the pump operating and the three-way valve in the bypass position, an austenitized part is placed in the lower section of the quench chamber. The air cylinders move the lower section up to the stationary upper section while locking and sealing the quench chamber in place. The three-way valve switches from the bypass to the quench position, and high-velocity water starts flowing through the quench chamber and over the austenitized part. When IQ is completed, the three-way valve switches back to the bypass position, and the water stops flowing through the quench chamber and again recirculates through the bypass line. The air cylinders open the quench chamber by moving the lower section down. The part is removed from the quench chamber lower section.

The major issue to be addressed when designing single-part quenching IQ-3 systems is to provide a high-velocity water flow uniformly around the entire part surface area. This is an especially difficult task when processing parts of complex geometry, which may cause the presence of stagnation zones at some areas of the part. The stagnation zones, in turn, may cause local film boiling, resulting in excessive part distortion. Computational fluid dynamic modeling is often required for designing an optimum quench chamber configuration in the case of complex-shaped parts processing (Ref 24).

Figure 19 presents a picture of a production high-velocity IQ system designed for processing helicopter gears. The IQ system is capable of also quenching shafts, rings, rollers, and other parts with maximum dimensions of 200 by 500 mm (8 by 20 in.) diameter. The IQ system is equipped with a water chiller for maintaining proper water temperature and an atmosphere box furnace for austenitizing the parts. The system is installed at the Euclid Heat Treating Co. of Cleveland, Ohio, USA. A similar production IQ system was developed for processing gun barrel steels and long shafts of

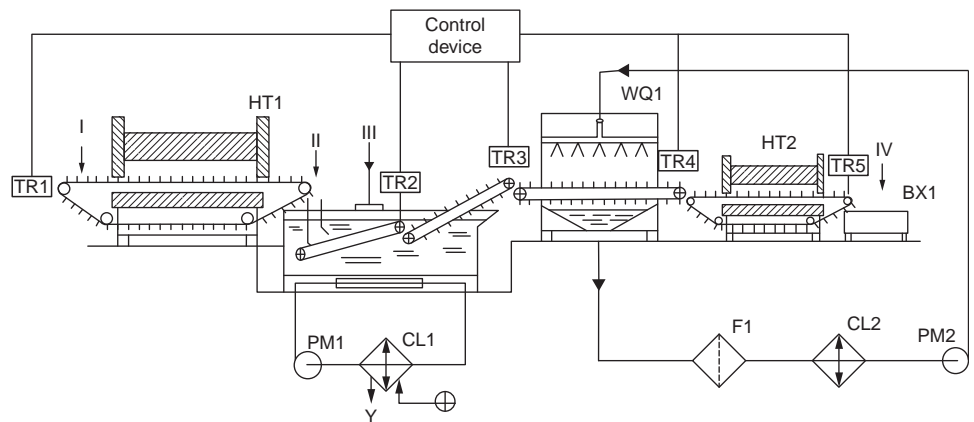

Fig. 17 Schematic of continuous-type intensive quenching system. I, loading point for steel parts onto the conveyor for heating in furnace HT1; II, chute with intensive cooling devices; III, quenching tank with two conveyors; IV, unloading point of steel parts from furnace HT2; TR1 to TR5, speed-control units for conveyor belts 1 to 5 operated by the control device; HT1 and HT2, furnaces 1 and 2; WQ1, washing and quenching device; PM1 and PM2, pumps 1 and 2; CL1 and CL2, chillers 1 and 2; F1, filter; BX1, container for heat treated parts. Source: Reprinted from Ref 3 with permission of ASTM International

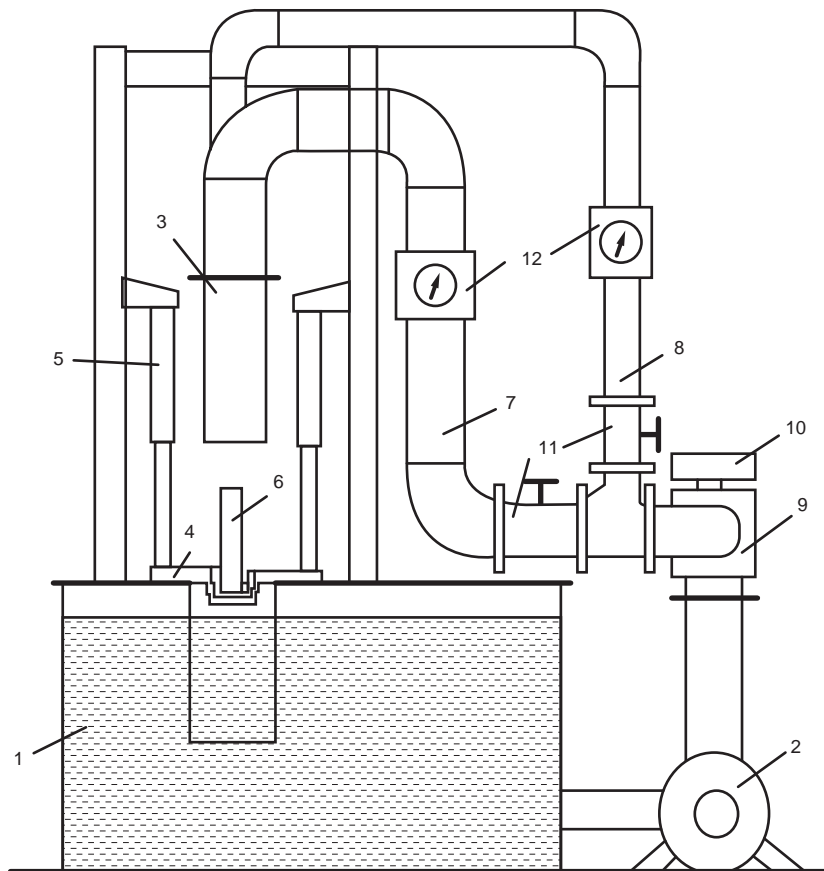

Fig. 18 Layout of typical single-part intensive quenching system. 1, water tank; 2, water pump; 3, stationary upper section of vertical quench chamber; 4, movable loading lower section of quench chamber; 5, air cylinders that move lower section up and down; 6, part to be quenched; 7 and 8, two of three water lines providing water flow through the quench chamber, and one bypass water line (not shown) used in idle conditions immediately before and after intensive quench dwell time of the part; 9, three-way valve providing water flow from the pump, either through the quench chamber or through the bypass line; 10, three-way valve actuator; 11, valves controlling water flow to quench chamber; 12, flow meters on water lines. Source: Reprinted from Ref 3 with permission of ASTM International

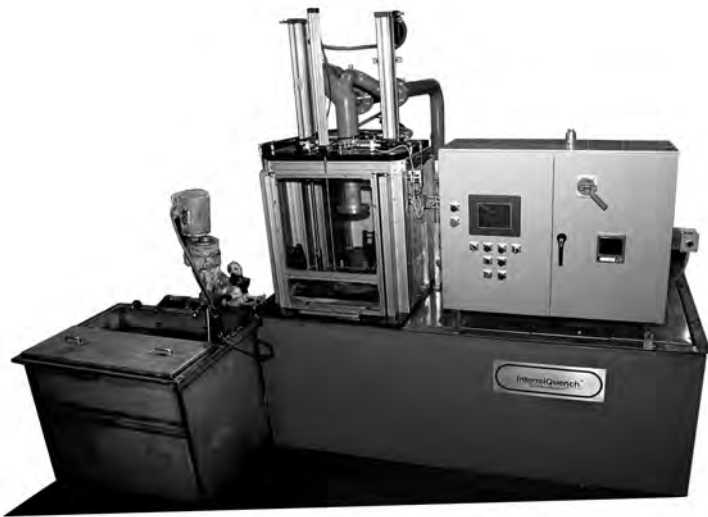

Fig. 19 Single-part production intensive quenching system for processing helicopter gears up to 200 by 480 mm (8 by 19 in.) diameter. Source: Ref 25

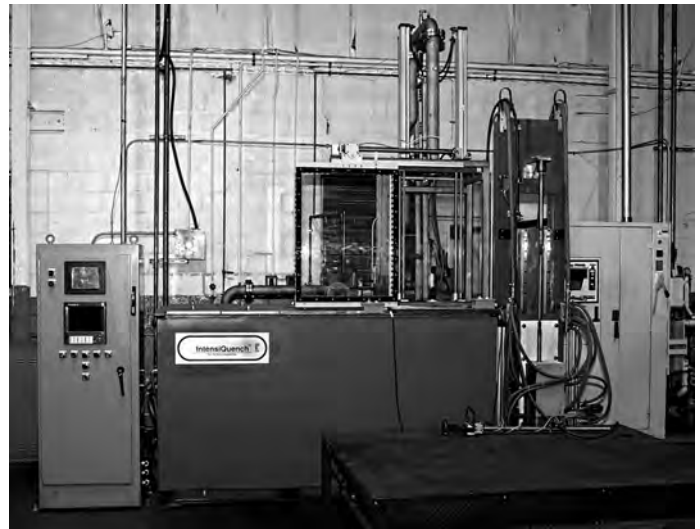







Fig. 20 Single-part production intensive quenching system for processing long shafts up to 50 mm (2 in.) diameter and 915 mm (36 in.) long. Source: Ref 25

Table 6 Practical applications of single-part intensive quenching process

Part	Improvement
 Automotive coil spring	Intensively quenched automotive coil springs made of 9259 and 9254 have longer fatigue life by 13 to 27% compared to the same springs quenched conventionally in oil, while intensively quenched lighter automotive coil springs have the same fatigue life as standard springs quenched in oil.
 Pulverizer coil spring	Intensively quenched pulverizer coil springs demonstrated 40% service life improvement in the field compared to the same springs quenched conventionally in oil.
 Output shaft	Heavy truck output shaft made of plain carbon 1040 steel and intensively quenched outperformed standard output shaft made of alloy 5140 steel and quenched in oil. Note that the use of plain carbon steel also provides material cost savings.
 Helicopter test gear	Intensively quenched helicopter test gears made of carburized Pyrowear-53 steel withstand 14% greater load for the same fatigue life as standard gears quenched in oil.
 Automotive side pinion	Automotive side pinion made of optimal-hardenability steel and quenched intensively demonstrated better fatigue performance compared to standard side pinion made of carburized 8620 steel and quenched in oil.
 Aluminum extrusion dies	Service life of intensively quenched aluminum extrusion dies made of hot work H-13 steel improves by at least 40%.

up to 50 by 910 mm (2.0 by 36 in.) diameter (Fig. 20). This system is equipped with an induction heating unit for austenitizing the parts prior to IQ.

Control and Automation Requirements. To run IQ processes successfully and to provide

process repeatability, the following parameters should be controlled:

- Water or water/salt solution flow velocity and temperature
- Water/salt solution concentration

- Control of dwell time—the duration of each stage of the IQ process







In IQ-2 systems that are equipped with high-volume propellers, measurement of the revolutions per minute and amperage draw for each propeller ensures uniform and repeatable quenchant flow through the workload. In IQ-3 systems, control valves and flow meters, along with properly designed part-holding fixtures, are used to adjust and control the water flow uniformity and velocity around the part surfaces being quenched.

One of the most important control elements for IQ processes is the duration or timing of quench and quench-interruption steps. The accuracy of controlling this parameter depends on the repeatability of the conveyer speed or lifting mechanism speed when applying IQ-2 processes. Also, for batch processing with IQ-2, proper part spacing is necessary to prevent film boiling between parts in the load. For IQ-3 systems, proper application of the IQ recipe depends on the time required by a three-way valve to switch from a bypass position to a high-velocity flow position and back, as well as on the time required to close and open the quench chamber. Because the duration of quench and quench-interruption steps is typically measured in seconds, all facets of the quench should be automated.

Practical Applications of IQ Processes

Over the years, the IQ processes were proved for a number of different steel products (automotive parts, forgings, castings, railroad equipment components, tool products, fasteners, etc.). Tables 6 and 7 show some examples of steel parts and the actual benefits obtained by applying batch-type or single-part IQ methods (Ref 4, 11, 12, 13–15, 17–20).

Table 7 Practical applications of batch-type intensive quenching process

Part	Improvement
	Automotive ball studs made of plain carbon 1040 and 1045 steels and intensively quenched have the same fatigue life as standard ball studs made of alloy 4140 steel and quenched in oil.
	Automotive universal joint crosses made of plain carbon 1018 steel and intensively quenched have the same or better performance characteristics as standard crosses made of alloy 5120 steel and quenched in oil. Note that the carburization cycle for the intensively quenched crosses was reduced by 15% compared to the standard cycle, resulting in process cost reduction as well.
	Cold work punches made of S5 steel improves service life by at least 2 times.
	Castings made of 8630 steel demonstrated the same or better mechanical properties as the same forged and oil-quenched parts.
	Steel mill rolls made of ductile iron and intensively quenched have greater service life compared to the same rolls quenched in oil.
	Forged rings made of 1045 steel and intensively quenched have less distortion compared to the same rings quenched in oil.

One of the major limitations for applying IQ processes is part dimension and shape. Part thickness should be adequate for developing a required temperature gradient throughout the part, necessary for formation of the high current and residual surface compressive stresses. A minimum permissible part thickness depends on the part shape as well as on the type of steel; steels of less hardenability and carburized grades of steel allow for less part thickness. Based on the results of numerous IQ process studies, the IQ method, in general, is not recommended for parts with thickness of less than 10 mm (0.4 in.). The IQ process is not applicable to parts with great thickness variation, because it is practically impossible to assign a cooling time suitable for all part sections. (The thin sections of the part could be cooled completely prior to quench interruption, resulting in excessive part distortion or even cracking.)

In summary, IQ processes have been shown to increase part hardness and strength, while at the same time providing the same or better material toughness versus traditional quenching methods on typical products made of various steel types. Manufacturers of steel parts can improve their product quality and reduce their costs by using the IQ processes. Some of the

proven advantages of intensive water quenching include:

- Higher surface hardness and core toughness with a greater hardened layer depth for parts made of carburized and noncarburized grades of steel
- Reduction of the carburization cycle for the same ECD (compared to oil quenching), resulting in the significant reduction of heat treatment processing costs and an increase of heat treating equipment production rate
- Improved part microstructure (finer grain and superstrengthened martensite)
- Greater and deeper residual surface compressive stresses
- Improved material strength and toughness (superstrengthening of steel)
- Substitution of lower-alloy steels for a reduction in part costs, yet no penalty to part strength or part performance
- Possibility of making high-power density parts—lighter parts with the same or better performance characteristics and fatigue life as oil-quenched parts due to the strengthening of the material and high residual surface compressive stresses provided by the IQ process
- Less part distortion and no part cracking

- Full elimination of quench oil and associated costs (cost of quench oil, part washing, etc.), resulting in a significant reduction of the heat treatment process cost and an improved environment
- Possibility of moving heat treatment operations into the manufacturing cell for rapid, part-by-part heat treating, because the intensive water-quenching method is an environmentally friendly process

REFERENCES

1. N.I. Kobasko and N.I. Prokhorenko, Quenching Cooling Rate Effect on Crack Formation of 45 Steel, *Metalloved. Term. Obrab. Met.*, No. 2, 1964, p 53–54 (in Russian)
2. M.A. Aronov, N.I. Kobasko, J.A. Powell, et al., “Practical Application of Intensive Quenching Technology for Steel Parts and Real Time Quench Tank Mapping,” Proceedings of 19th ASM Heat Treating Society Conference (Cincinnati, OH), 1999
3. N.I. Kobasko, M.A. Aronov, J.A. Powell, and G.E. Totten, *Intensive Quenching Systems: Engineering and Design*, ASTM International, 2010
4. M.A. Aronov, N.I. Kobasko, and J.A. Powell, “Application of Intensive Quenching Methods for Steel Parts,” Proceedings of the 21st ASM Heat Treating Conference (Indianapolis, IN), 2001
5. N.I. Kobasko, *Steel Quenching in Liquid Media under Pressure*, Naukova Dumka, Kiev, 1980 (in Russian)
6. L.L. Ferguson, private communication, Aug 2012
7. “Predictive Model and Methodology for Heat Treatment Distortion,” NCMS Report 0383RE97, National Center for Manufacturing Sciences, Ann Arbor, MI, Sept 30, 1997
8. W.M. Rohsenow, J.P. Harnett, and Y.C. Cho, *Handbook of Heat Transfer*, 3rd ed., McGraw-Hill Handbooks, 1998
9. M.P. Muhina, N.I. Kobasko, and L.V. Gordejewa, Hardening of Structural Steels in Chloride Quench Media, *Metalloved. Term. Obrab. Met.*, Sept 1989, p 32–36 (in Russian)
10. M.A. Aronov, N.I. Kobasko, J.F. Wallace, and D. Schwam, “Experimental Validation of the Intensive Quenching Technology for Steel Parts,” Proceedings of the 18th ASM Heat Treating Conference (Chicago, IL), 1998
11. M.A. Aronov, N.I. Kobasko, J.A. Powell, J.F. Wallace, and D. Schwam, “Experimental Study of Intensive Quenching of Punches,” Proceedings of 19th ASM Heat Treating Society Conference (Cincinnati, OH), 1999
12. M.A. Aronov, N.I. Kobasko, and J.A. Powell, “Practical Application of Intensive Quenching Process for Steel

- Parts,” Proceedings of the 20th ASM Heat Treating Conference (St. Louis, MO), 2000
13. M.A. Aronov, N.I. Kobasko, and J.A. Powell, “Basic Principles and Metallurgy of Intensive Quenching Methods,” Proceedings of the 13th IFHTSE Congress (Columbus, OH), 2002
 14. M.A. Aronov, N.I. Kobasko, and J.A. Powell, “Intensive Quenching Technology for Tool Steels,” Proceedings of the 13th IFHTSE Congress (Columbus, OH), 2002
 15. M.A. Aronov, N.I. Kobasko, J.A. Powell, P. Ghorpade, and D. Gopal, “Application of Intensive Quenching Processes for Carburized Parts,” Proceedings of 22nd ASM Heat Treating Conference (Indianapolis, IN), 2003
 16. M.A. Aronov, N.I. Kobasko, J.A. Powell, J.F. Wallace, and Y. Zhu, “Effect of Intensive Quenching on Mechanical Properties of Carbon and Alloy Steels,” Proceedings of the 23rd ASM Heat Treating Conference (Pittsburgh, PA), 2005
 17. A.M. Freborg, Z. Li, B.L. Ferguson, and D. Schwam, “Bending Fatigue Strength Improvement of Carburized Aerospace Gears,” Proceedings of the 23rd ASM Heat Treating Conference (Pittsburgh, PA), 2005
 18. C.R. Hubbard, F. Tang, M.A. Aronov, N.I. Kobasko, et al., “Effect of Intensive Quenching on Residual Stress,” Proceedings of 23rd ASM Heat Treating Conference (Pittsburgh, PA), 2005
 19. M.A. Aronov, N.I. Kobasko, J.A. Powell, and P. Ghorpade, “Demonstrations of Intensive Quenching Methods for Steel Parts,” Proceedings of 24th ASM Heat Treating Conference (Detroit, MI), 2007
 20. B.L. Ferguson, A.M. Freborg, and Z. Li, “Improving Gear Performance by Intensive Quenching,” Proceedings of 24th ASM Heat Treating Conference (Detroit, MI), 2007
 21. N.I. Kobasko, “Effect of Structural and Thermal Stresses on Crack Formation during Steel Quenching,” Proceedings of All-Union Conference on Increase of Productivity and Profitability of Heating Furnaces (Dnepropetrovsk, Ukraine), 1967
 22. B.L. Ferguson and A.M. Freborg, “Use of Computer Simulation in Optimizing Intensive Quenching Process,” Proceedings of the 2002 IFHTSE Congress (Columbus, OH), 2002
 23. B.L. Ferguson, A.M. Freborg, and Z. Li, “Residual Stress and Heat Treatment—Process Design for Bending Fatigue Strength Improvement of Carburized Aerospace Gears,” European Conference on Heat Treatment (Berlin), 2007
 24. A. Banka, J. Franklin, B.L. Ferguson, Z. Li, and M. Aronov, “Applying CFD to Characterize Gear Response during Intensive Quenching Process,” Proceedings of 24th ASM Heat Treating Conference (Detroit, MI), 2007
 25. M.A. Aronov, N. I. Kobasko, J.A. Powell, and P. Sampson, Intensive Quenching Process Commercialization, *Ind. Heat. J.*, Oct 2012